

MASTER PART MARK	VIN	AVAILABLE THICKNESS	YIELD MIN.	BLANK LENGTH	BLANK WIDTH	WEIGHT (LBS)
H4640	B	22 GA	33 KSI	NA	NA	0.56

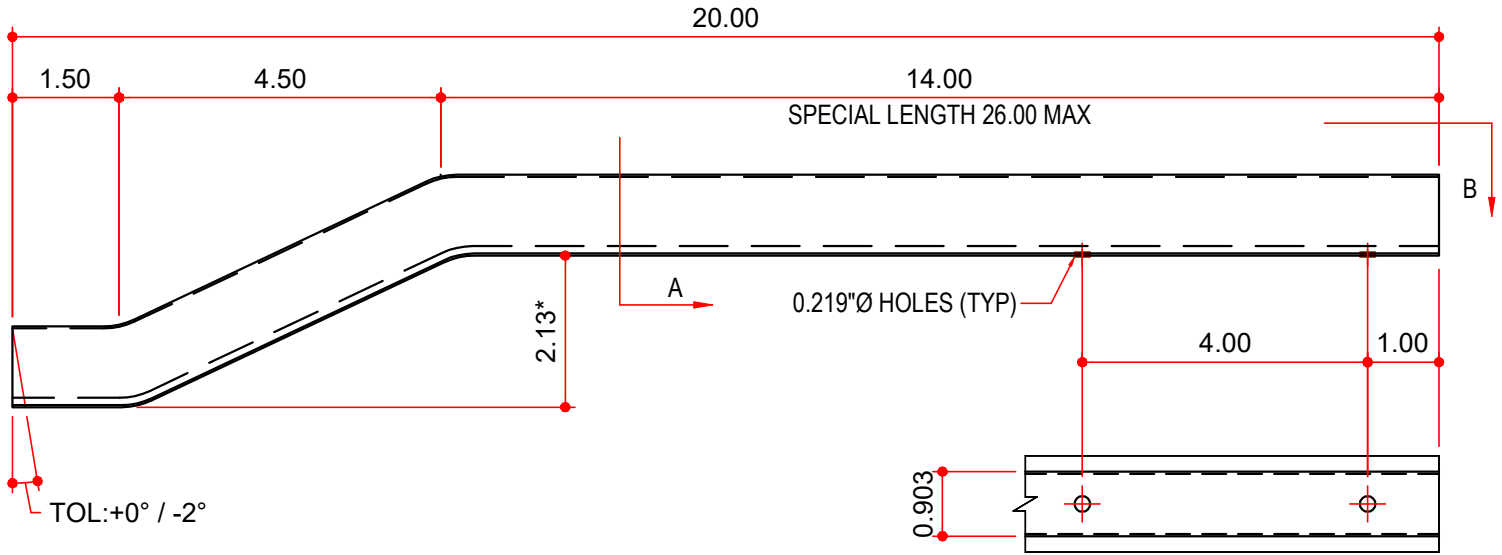

SECTION B

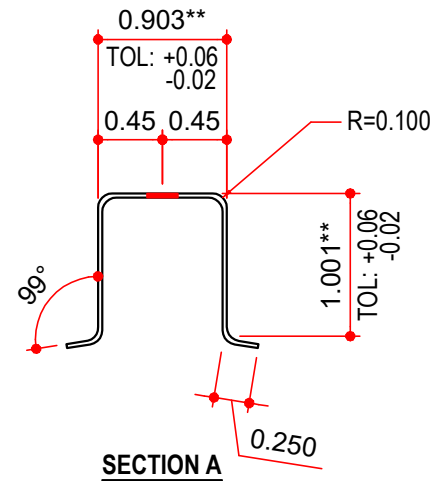

MATERIAL:

0.029 (22 GA), GALVALUME AZ55 COATING.

NOTES:

- 1) ALL DIMENSIONS TO CORNER INTERSECTION POINTS U.N.O.
- 2) ** - OUT TO OUT DIMENSION.
- 3) * - HOLD DIMENSION.
- 4) ANGLES - $\pm 2^\circ$ U.N.O.
- 5) ALL RADII ARE 0.060" TO INSIDE BEND, U.N.O..RADII TOL. ARE ± 0.02 ".
- 6) ALL DIMENSIONS ARE $\pm .063$ U.N.O.

NOTES: BUYOUT

- 1) ALL BENDS ARE 90° UNO
- 2) FOR SPECIAL PANEL OVERHANGS AND SKEWED WALLS, AN EXTRA LONG GUTTER BRACKET IS AVAILABLE THROUGH A SPECIAL ORDER. A PURCHASE REQUEST AND PART DRAWING WILL BE REQUIRED. CONTACT YOUR DIVISIONAL PURCHASING DEPT.

AVAILABLE COLORS

ALL STANDARD SMP & PVDF COLORS