

MASTER PART MARK	VIN	AVAILABLE THICKNESS	YIELD MIN.	BLANK LENGTH	BLANK WIDTH	WEIGHT (LBS)
H2210	A	18 GA	33 KSI	9.13	7.00	0.62

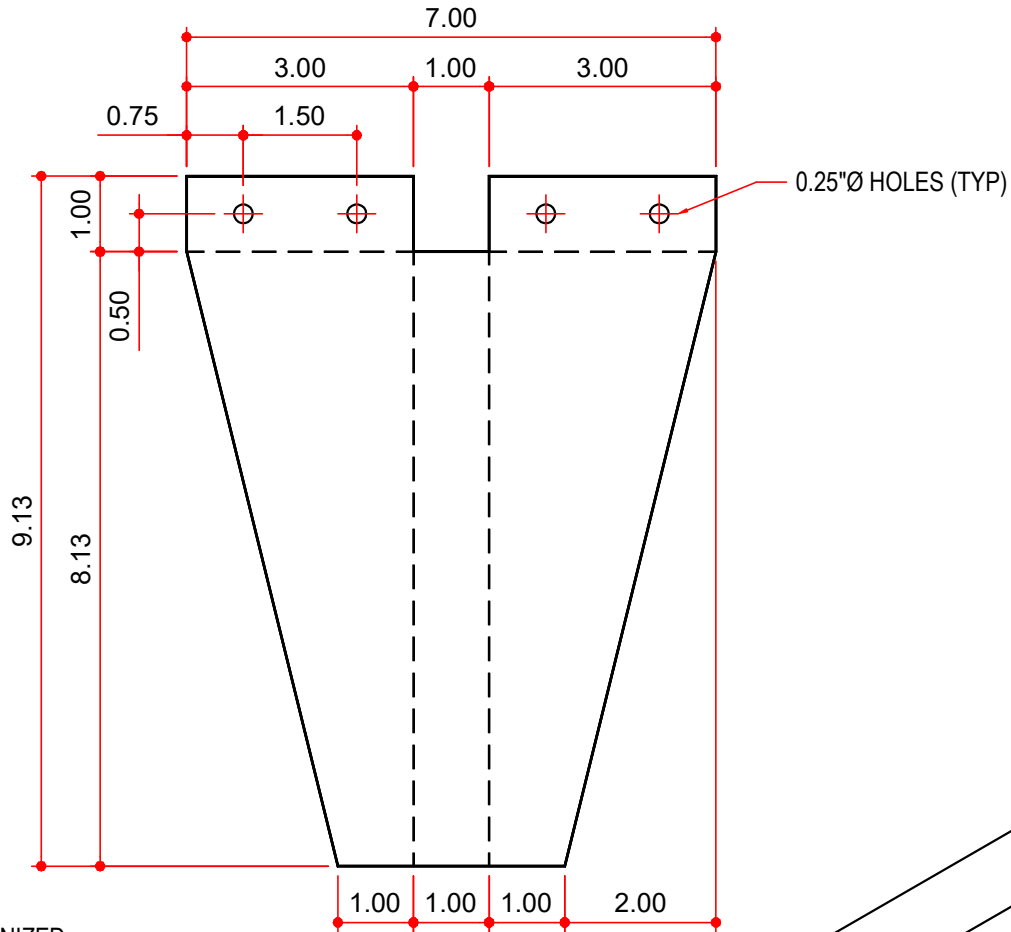

MATERIAL:
0.048 (18 GA), ALUMINIZED.

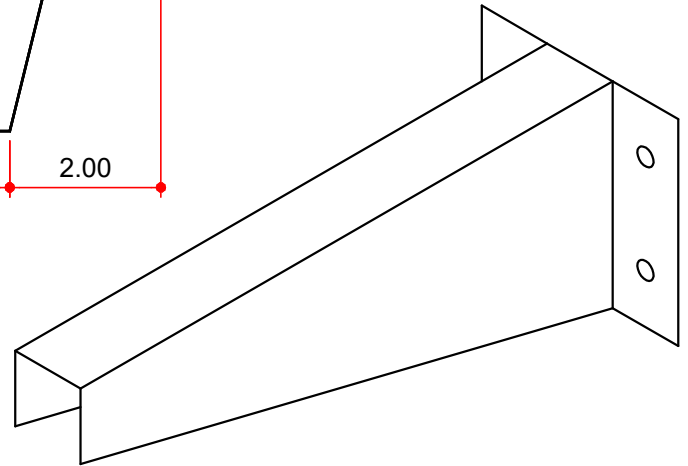

NOTES: BUYOUT

- 1) ALL BENDS ARE 90° UNO
- 2) IF A SPECIAL GUTTER SIZE (WIDTH) IS USED A SPECIAL BRACKET WILL BE REQUIRED. SPECIAL BRACKETS WILL NEED TO BE MADE IN HOUSE OR ORDERED SPECIAL FROM THE SUPPLIER.

AVAILABLE COLORS

NP