

MASTER PART MARK	VIN	AVAILABLE THICKNESS	YIELD MIN.	BLANK LENGTH	BLANK WIDTH	WEIGHT (LBS)
H2190	D	0.060	33 KSI	NA	NA	0.92

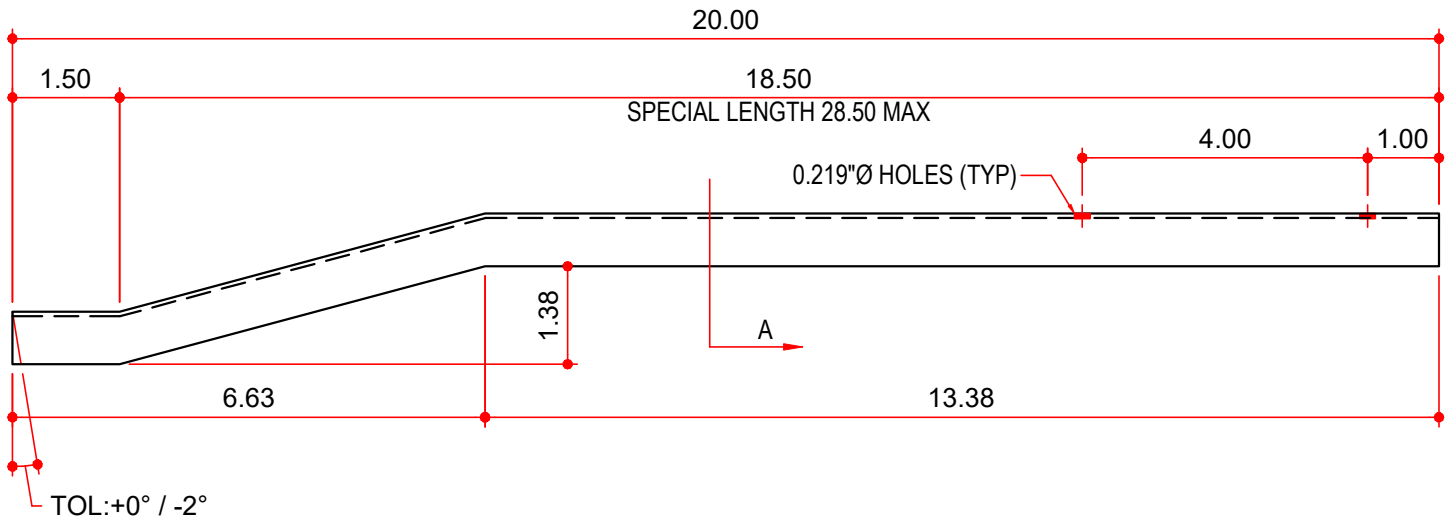

MATERIAL:
0.060 (16 GA), GALVALUME AZ55 COATING.

- NOTES:**
- 1) ALL DIMENSIONS TO CORNER INTERSECTION POINTS U.N.O.
 - 2) ANGLES - ±2" U.N.O.
 - 3) ALL DIMENSIONS ARE ±.063 U.N.O.

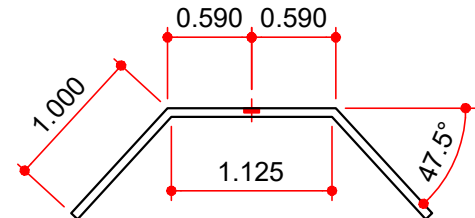

NOTES: BUYOUT

- 1) ALL BENDS ARE 90° UNO
- 2) FOR SPECIAL PANEL OVERHANGS AND SKEWED WALLS, AN EXTRA LONG GUTTER BRACKET IS AVAILABLE THROUGH A SPECIAL ORDER. A PURCHASE REQUEST AND PART DRAWING WILL BE REQUIRED. CONTACT YOUR DIVISIONAL PURCHASING DEPT.

AVAILABLE COLORS

ALL STANDARD SMP & PVDF COLORS