

MASTER PART MARK	VIN	AVAILABLE THICKNESS	YIELD MIN.	BLANK LENGTH	BLANK WIDTH	WEIGHT (LBS)
H2051	C	0.060	33 KSI	N/A	1.50	0.56

NOTE:

MANUFACTURING TOLERANCE: ± 0.025
INSIDE RADII U.N.O.: 0.060

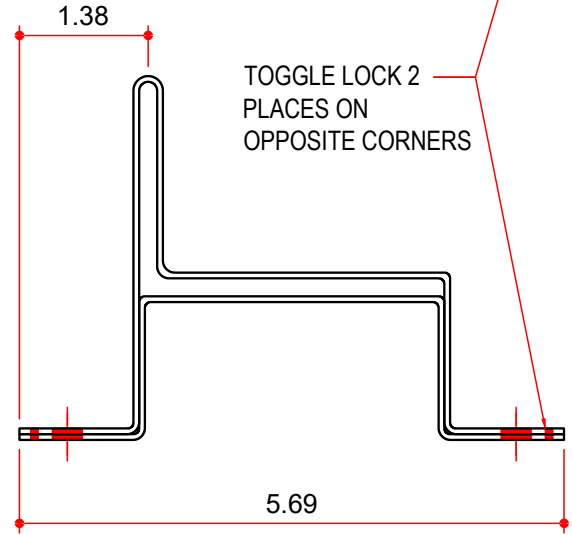
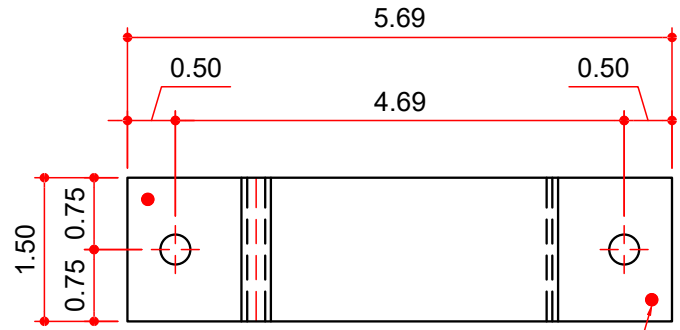
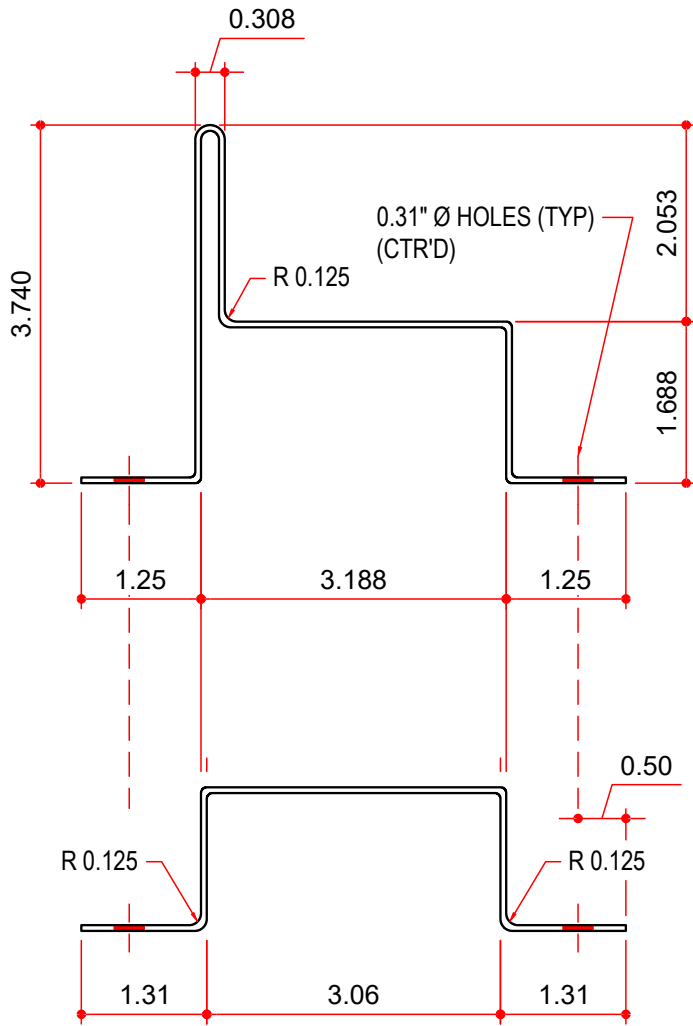

NOTES: **BUYOUT**

1) ALL BENDS ARE 90° UNO

AVAILABLE COLORS

NP