

MASTER PART MARK	VIN	AVAILABLE THICKNESS	YIELD MIN.	BLANK LENGTH	BLANK WIDTH	WEIGHT (LBS)
DSCEAA	A	26 GA	33 KSI	16.00	17.563	1.55
DSCEAB	A	26 GA	33 KSI	16.00	17.563	1.55
DSCEBA	A	26 GA	33 KSI	16.00	17.563	1.55
DSCEBB	A	26 GA	33 KSI	16.00	17.563	1.55

**"A" STYLE**

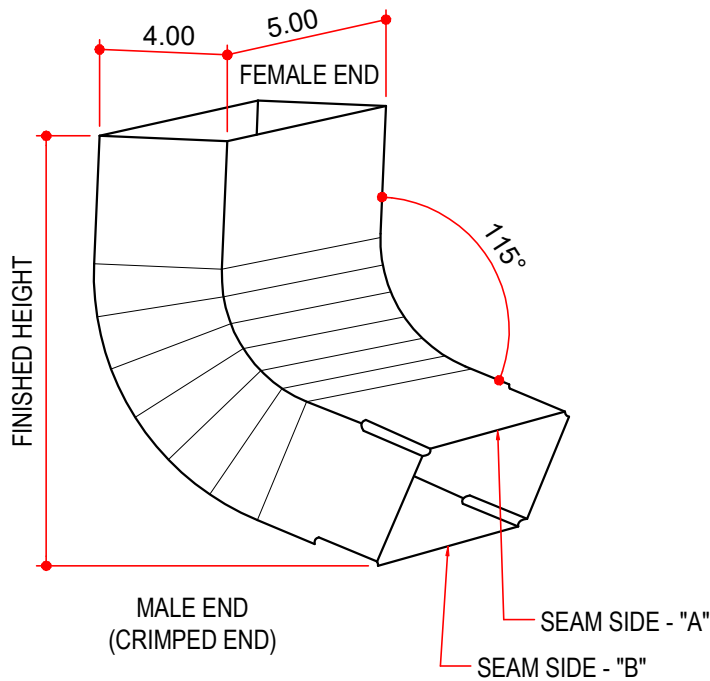

**"B" STYLE**

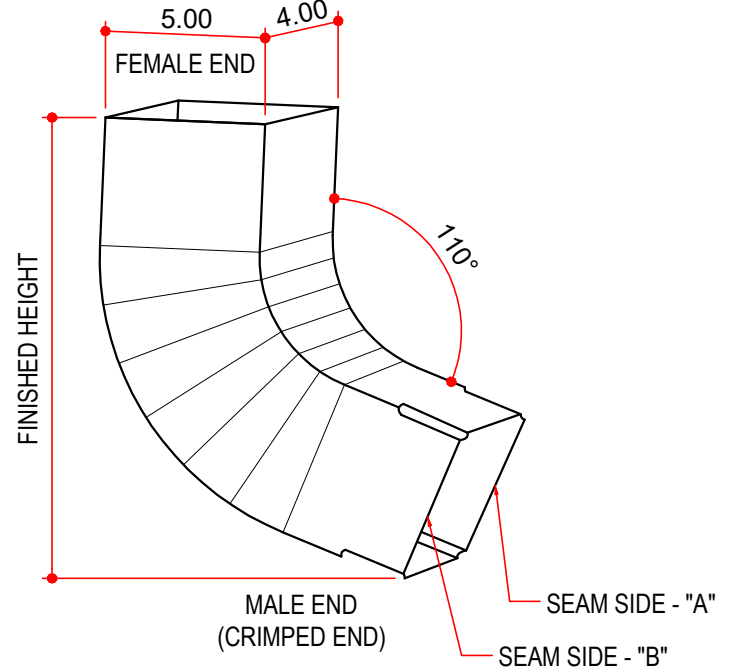

DSCE\_\_

- ├── A = SEAM SIDE "A" - SEE PIC
- ├── B = SEAM SIDE "B" - SEE PIC
- ├── A = "A" STYLE ELBOW
- ├── B = "B" STYLE ELBOW
- └── DOWNSPOUT CORRUGATED ELBOW

PART NUMBER	DESCRIPTION	FINISHED HEIGHT	SEAM SIDE	NOTES
DSCEAB	"A" STYLE SEAM SIDE "B"	11.50	B	1 & 3
DSCEAA	"A" STYLE SEAM SIDE "A"	11.50	A	1 & 3
DSCEBB	"B" STYLE SEAM SIDE "B"	14.00	B	1 & 3
DSCEBA	"B" STYLE SEAM SIDE "A"	14.00	A	1 & 3

**NOTES:**

- 1) CHECK LOCAL DIVISION FOR PART AVAILABILITY.
- 2) EXTENDED LEAD TIMES CAN APPLY IF THE DIVISION RUNS OUT OF STOCK. IT TAKES 6-8 HOURS FOR TOOLING CHANGE REQUIRED TO PRODUCE THESE PARTS. THEY ARE ONLY RUN IN BATCHES A COUPLE OF TIMES A YEAR IN A LIGHT AND DARK COLOR, THEN HAND PAINTED TO ORDER.
- 3) GM COLOR OPTION NOT AVAILABLE AT ALL MFG LOCATIONS, CHECK WITH PURCHASING / PRODUCTION.

**AVAILABLE COLORS**

ALL STANDARD SMP & PVDF COLORS