

FABRICATION MANUAL

SHIP PC-MK:

SECTION: **19**

NOTE: FOR USE WITH 10" PURLINS

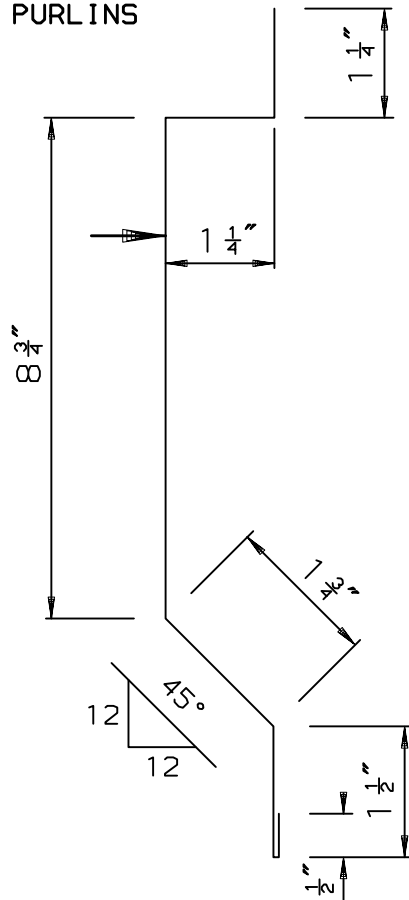

GENERATED PART NUMBER DESCRIPTION

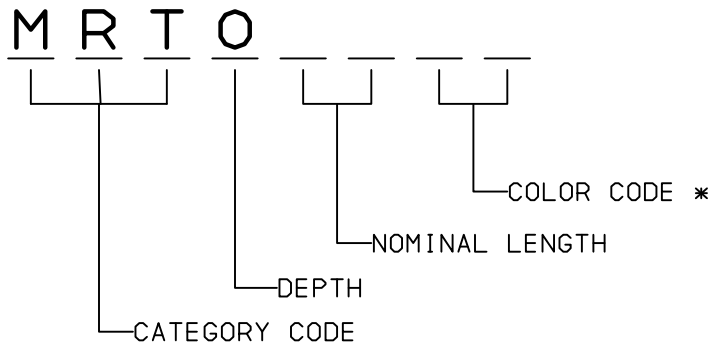

* SEE TRIM SECTION
COVER PAGE FOR
COLOR CODES

DESC. OF DWG: **10" MASONRY RAKE TRIM**

BLANK WIDTH=15" MATERIAL=26 GA. WT. PER LIN. FT. = .78# MAX. LENGTH =20'3"

ACTUAL LENGTH = NOMINAL LENGTH + 3".

PREPARED BY: R. LAWSON

CHECKED BY:

DATE: 30-APR-03



BUILDING SYSTEMS
A DIVISION OF ASSOCIATED BUILDING SYSTEMS, INC.

M R T O

COMPUTER SERVICES NUMBER: **FM_MRTO**