

FABRICATION MANUAL

SHIP PC-MK:

SECTION: **18**

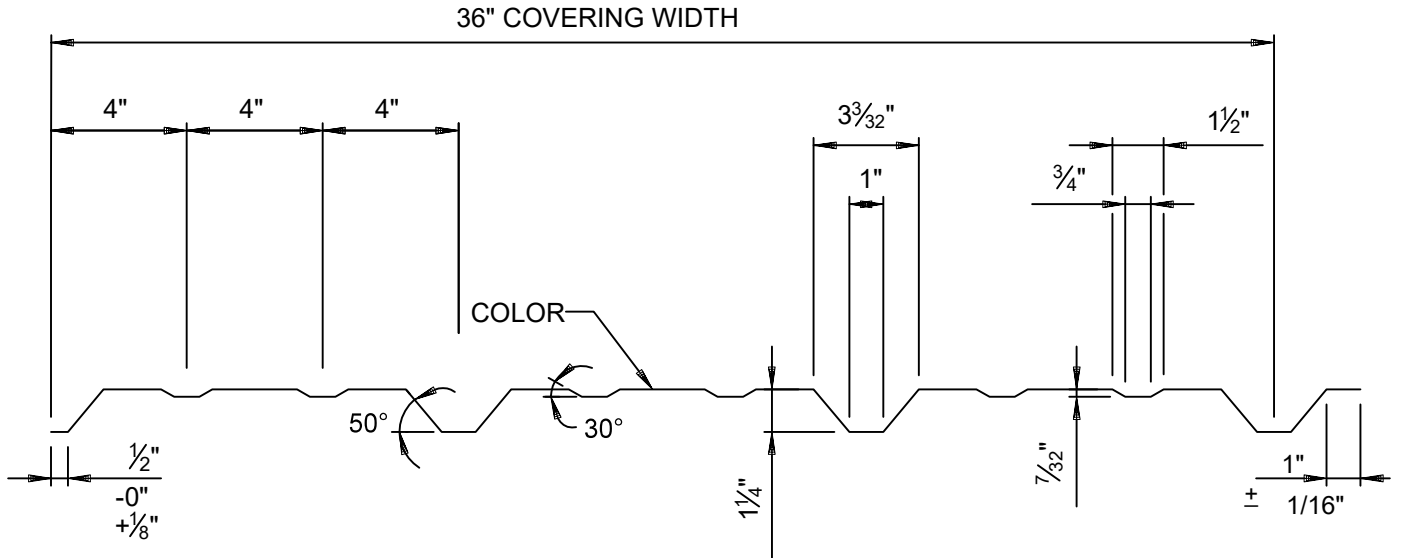

FL. PRODUCT APPROVAL
4837.3

STOCK PART NUMBER DESCRIPTION

K R P A

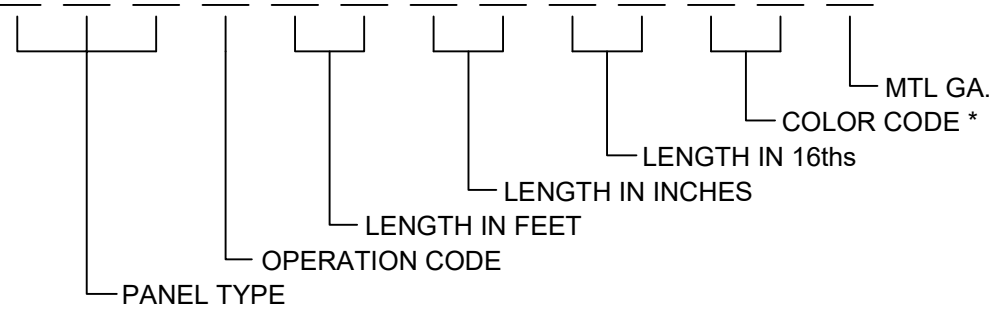

* SEE PANEL SECTION
COVER PAGE FOR
COLOR CODES

GAGE	CODE	WT. PER FT.	END VIEW
26 GA.	6	2.76	<p style="text-align: center;">NOTE: BEARING EDGE ON RIGHT</p>
24 GA.	4	3.35	
*22 GA.	2	4.32	
*SPECIAL ORDER			

1) MAX. LENGTH = 41'0"

2) COIL WIDTH = 42³/₄"

DESC.OF DWG: REVERSE ROLL PANEL

PREPARED BY: BKC

DATE: 2-18-15



KRP