



STEEL BUILDINGS

CUSTOMER _____

CBC JOB NO. _____

L-4

DESIGNER _____

DRAWN _____

SHOP SPCL. CONDITIONS

DATE _____

DATE _____

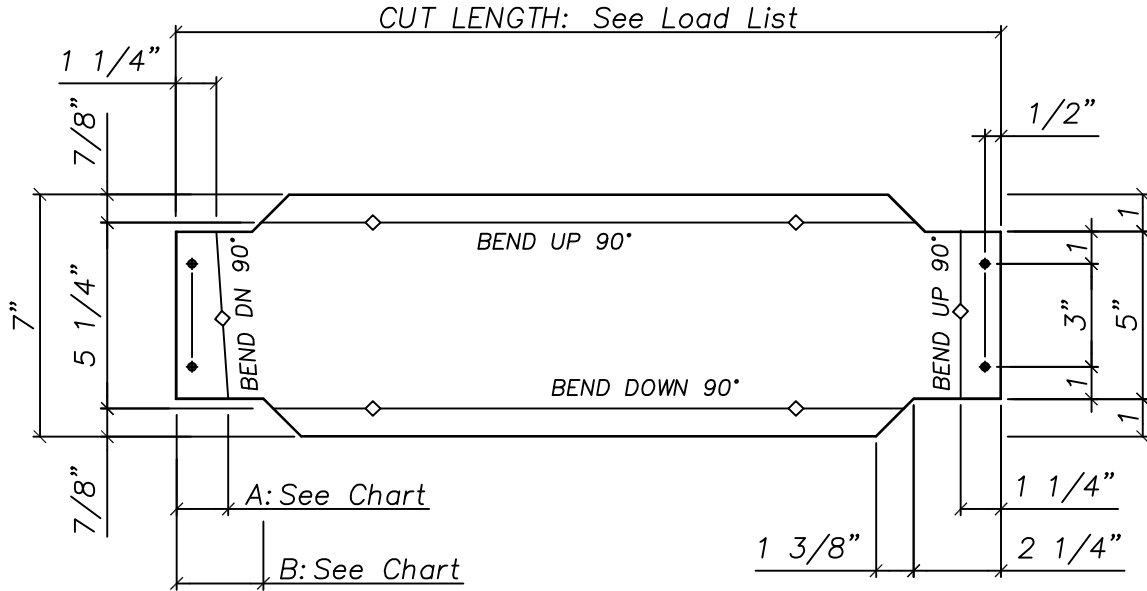

1/4"Ø HOLES

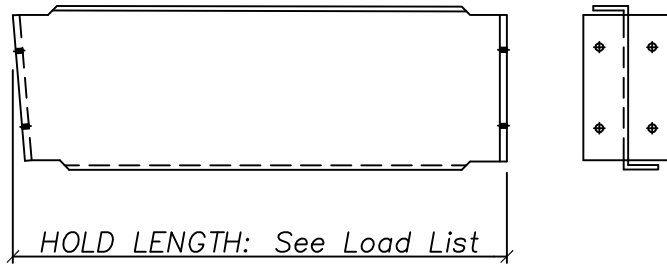

PITCH	A	B
1/2:12	1 7/16"	2 1/4"
1 :12	1 11/16"	2 1/4"
1 1/2:12	1 7/8"	2 1/4"
2 :12	2 1/16"	2 1/4"
2 1/2:12	2 5/16"	2 3/4"
3 :12	2 1/2"	3"
3 1/2:12	2 11/16"	3 1/4"
4 :12	2 15/16"	3 1/2"
4 1/2:12	3 1/8"	3 5/8"
5 :12	3 3/8"	3 7/8"
5 1/2:12	3 9/16"	4"
6 :12	3 3/4"	4 1/4"

EAVE BLOCKING (:12)

MAT'L: 16 Ga. Galv.

BLANK WIDTH: 7"

MARK#	LENGTH	QTY.
EB-		