

Mark Number	Material	Thk.	TREC A Width	TREC A Length	Weight A	TREC B Width	TREC B Length	Weight B	Total Weight
TRUECL	CS Type B	26 Ga.	8 1/4	8 1/8	0.34	5 5/16	2 7/8	0.08	0.42
TRUECR	CS Type B	26 Ga.	8 1/4	8 1/8	0.34	5 5/16	2 7/8	0.08	0.42

**Notes:** All Bends 90° U.N.    **Holes:** 9/16"φ U.N.    **Slots:** 9/16" X 7/8" U.N.    **Color:** SEE TALLY

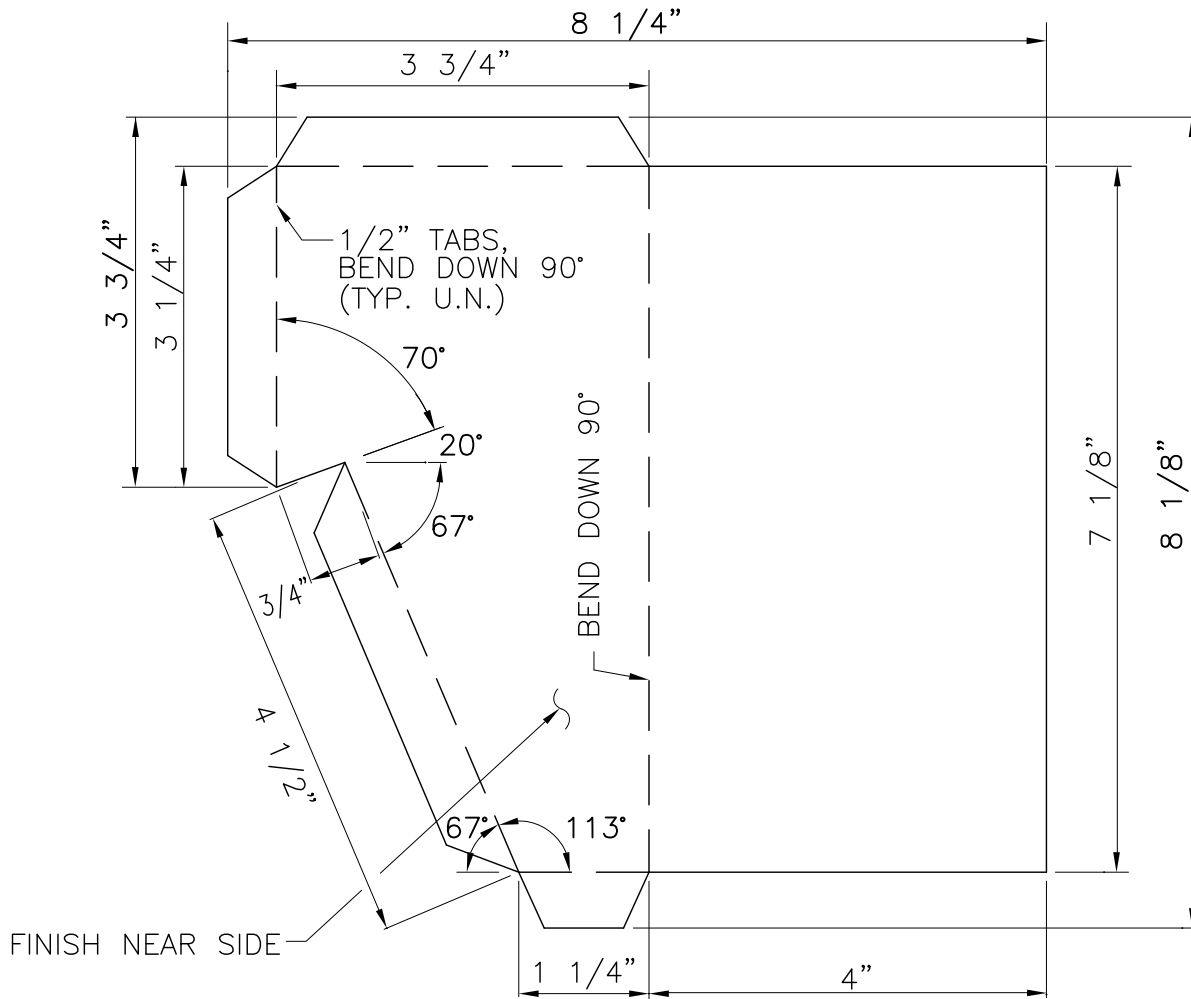

TRUEC A (RIGHT HAND AS SHOWN, LEFT HAND OPPOSITE)

**SHOP NOTE:**  
SHIP TOGETHER AS UNIT.

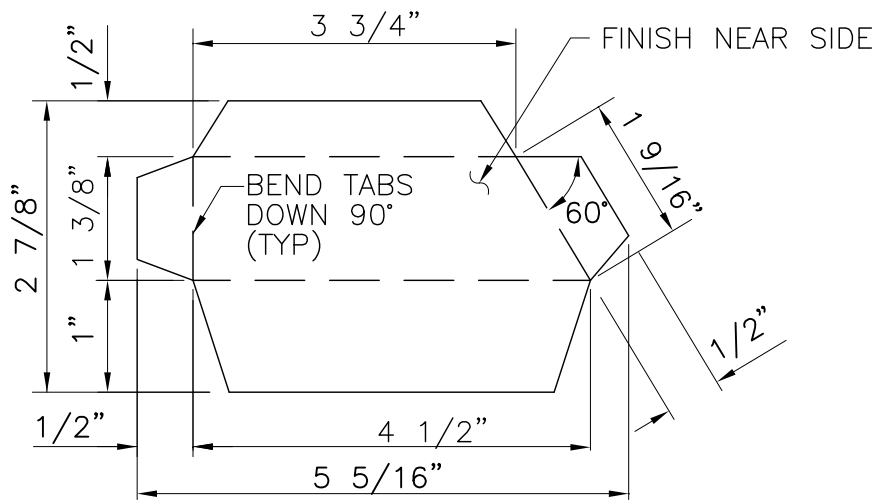

TRUEC B (RIGHT HAND AS SHOWN, LEFT HAND OPPOSITE)

<b>Issued</b>	6-29-15	<b>Release No.</b>	<b>Revision No.</b>	<b>Description</b>
<b>Drawn By</b>	WHH	PB.05.2015	0	Rake Endcap
<b>Checked By</b>	THG			



AMERICAN BUILDINGS COMPANY

**Parent Mark Number**

**TRUEC\_**